

UDC 687.4: 640.4: 7.021.5

DOI: 10.15587/1729-4061.2018.121507

PREREQUISITES FOR THE DEVELOPMENT OF HYDRO-JET TECHNOLOGY IN DESIGNING WOMEN'S HEADGEAR AT HOSPITALITY ESTABLISHMENTS

Обґрунтовано вибір затопленого гідроструменя як інструменту для формування об'ємних деталей головних уборів. Розроблено експериментальний прилад та метод для визначення динамічних тисків затопленого гідроструменя. Досліджено вплив геометричних параметрів коноїдальних струменеформуючих насадків з круглими та еліптичними вихідними отворами на величину динамічних тисків утворених ними затоплених гідроструменів. Проведено дослідження та встановлено експериментальні значення динамічних тисків гідроструменя і середнє значення коефіцієнта втрат

Ключові слова: гідроструминна технологія, жіночі головні убори, дизайн-проекування, формування деталей головних уборів, затоплений гідрострумінь

Обоснован выбор затопленной гидроструи как инструмента для формирования объемных деталей головных уборов. Разработан экспериментальный прибор и метод для определения динамических давлений затопленной гидроструи. Исследовано влияние геометрических параметров коноидальных струеформирующих насадок с круглыми и эллиптическими выходными отверстиями на величину динамических давлений образованных ими затопленных гидроструй. Проведены исследования и установлены экспериментальные значения динамических давлений гидроструи и среднее значение коэффициента потерь

Ключевые слова: гидроструйная технология, женские головные уборы, дизайн-проектирование, формирование деталей головных уборов, затопленная гидроструя

O. Yakymchuk
PhD, Associate Professor*

D. Yakymchuk
PhD, Associate Professor**
E-mail: starcon84@gmail.com

N. Kushevskiy
PhD, Professor***
E-mail: kushevskiy@mail.ru

E. Chepelyuk
Doctor of Technical Sciences, Professor*

J. Koshevko
PhD, Associate Professor***
E-mail: juliakoshevko@gmail.com

N. Myrhorodska
PhD, Associate professor*
E-mail: myrhorodska@i.ua

O. Dzyundzya
PhD, Associate Professor**
E-mail: Dzokvaok@gmail.com

V. Burak
PhD, Associate Professor
Department of food production engineering
Kherson State Agricultural University
Stritenska str., 23, Kherson, Ukraine, 73006
E-mail: burak_v@ro.ru
*Department of design
Kherson National Technical University
Berislavske highway, 24, Kherson, Ukraine, 73008
**Department of hotel and restaurant business
Kherson State University
40 rokiv Zhovtnya str., 27, Kherson, Ukraine, 73000
***Department of technology and design of garments
Khmelnyskiy National University
Instyitska str., 11, Khmelnytskyi, Ukraine, 29016

1. Introduction

Headgear as an element of the women's thematic and image costume can be either basic or a continuation of a particular idea or an image. Most often, the headgear is thematically

selected to match the costume and is frequently made from similar material.

Modern women's headgear at hospitality establishments are characterized by a variety of shapes and materials. The most common are those of round and oval shape, which can

be explained by low complexity of manufacturing and low costs. However, when using different materials, difficulties can occur during forming, fastening and shaping.

The market of light industry goods to the full extent satisfies the demand of consumers for headgear made of fur, leather and felt, as well as headgear, sewn from fabric, which is shaped in a constructive way. However, multi-operation and energy-consuming technologies are used for manufacturing of the specified products. In addition, there are no models of shaped headgear from fabric on sale, which is often the cause of mismatch of headgear and the style, color, and texture of coats, dresses and costumes.

Development of a new technology of shaping details of headgear from fabric requires a unified, scientifically substantiated method, which is based on a comprehensive approach to the systems of technological preparation of production and designing of high-performance equipment.

Modern fashion is characterized by a variety of headgear shapes. In shaping of voluminous headgear details, deformation of the flat piece of fabric and giving it a desired complex voluminous shape is the most difficult task. This is difficult to achieve by maximal use of deformation properties of a complex action of working medium and applied mechanical loads.

The use of fluid-active working medium (FAWM) has been recently proposed for shaping voluminous headgear details. However, in the designed technologies, there is no local influence of the force field on certain sections of a detail, which is necessary for shaping such complex and various voluminous shapes as headgear details.

The use of the submerged hydro-jet offers a wide range of opportunities for application of little-operational and energy-saving technologies, as well as for improvement of methods for shaping voluminous headgear details due to the influence of concentrated load on the fabric. Hydro-jet technologies are widely used in various industries, including construction, machine building, light industry, electronics, mining, etc.

Development of a new technology for shaping headgear details of a complex voluminous shape with the use of the concentrated influence of the controlled submerged hydro-jet is a relevant problem. This technology can provide a match of headgear item and clothing elements, used at hospitality establishments [1, 2]. At the same time, headgear design with the use of modern technologies of shaping will contribute to enhancing competitiveness of many related industries.

2. Analysis of application of hydro-jet technologies in various industries

The use of high pressure jets as a tool has become common in many sectors of economy. They include food industry, construction, machine building, aviation and space technology, optics, light industry, woodworking, electronics, atomic power engineering, shipbuilding, and shipping, petrochemicals, ecology, mining, medicine, and many others. This is explained by the fact that hydro-jet technologies provide a wide range of technological operations (cutting, milling, washing, transportation, treatment of surfaces: cleaning and polishing, sharpening, and boring). Hydro-jet is known to be used for breaking copper ores by a high pressure jet [3], as well as for destruction of brittle materials by the method

of hydro-jet treatment [4]. Optimization of parameters of the process of high pressure water jet [5] provides sufficient destruction of rocks. Conducted numerical simulation of turbulent cavitation water jets, released from a submerged nozzle [6] allows description of the process of hydro-jet destruction. A lot of studies characterize water jet strength [7], its structure and erosion characteristics [8] and describe cavitation processes of hydro-jet treatment of different materials [9]. However, the explored studies do not give a clear idea about the influence of a water jet on shaping women's headgear at hospitality institutions.

Hydro-jet technologies provide treatment of both soft and hard materials, such as cardboard, fabric, wood, leather, rubber, ceramics, steel, hard alloys, and rocks [10].

According to the methods of influence on material, the following hydro-jet technologies are distinguished: pulsating, pulse, cavitation, and continuous technology.

For cutting and treatment of materials, they use hydro plants with capacity from 8 to 80 kW, which provide jet flowing pressure from 150 to 1,000 MPa and higher, which corresponds to jet velocity from 540 to 1,400 m/s [10].

It is known, that various processes, each of which can lead to destruction, are caused by the influence of ultra-jets [11]. The methods of obtaining ultra-jets can be different and include fluid displacement through a small opening and using one-dimensional and spatial wave effects.

Displacement of fluid through the opening (extrusion) is used in a pulse water jet cutter. A shoot occurs as a result of piston impact. Water, compressed by a piston, flows out of the nozzle at high velocity. The duration of a shoot is a few milliseconds. Later, there appeared the idea of electro-pulse water jet cutter, in which fluid flowing is caused by one-dimensional wave process. In this case, a vapor-gas cavity, which originated as a result of electrical discharge in the water, acts as a piston. In this case, jet pressure is 200–1,400 MPa at duration of the process of a few microseconds [11].

The wave process, close to one-dimensional, was implemented in a hydro-gun. A jet is formed by the inertia principle, which lies in re-distribution of energy in the flow of non-stationary moving fluid. The air was preliminarily pumped out of the nozzle. The water, driven by the piston, reaches the inlet of the nozzle and flows into it with acceleration. The duration of a shoot is less than one millisecond [11].

Lately, detail stamping by hydro-explosion has been widely applied in machine building [12]. Water is used as working medium that transmits pressure from the charge of the explosive to a workpiece. It should be noted that an increase in the mass of the charge of the explosive or a decrease in the distance from the charge to a workpiece can lead to rupture of the latter. In this case, the cracks that appear on the inner surface of a detail are of brittle destruction nature.

The use of pulse technologies is characterized by short duration of the process at significant pressures, which basically leads to destruction of the surface of material that is treated (Fig. 1).

Pulse technologies did not find further application in industry for the following reasons: energy of influence of force field, created by pulse loads, is negligible despite the maximum efforts, applied to implementation of this process. That is why pulse load is advisable to apply for destruction of brittle materials (glass cutting) or «non-viscous» (fabric).

Cavitation hydro-jet technologies have a destructive impact on the treated material [13, 14].

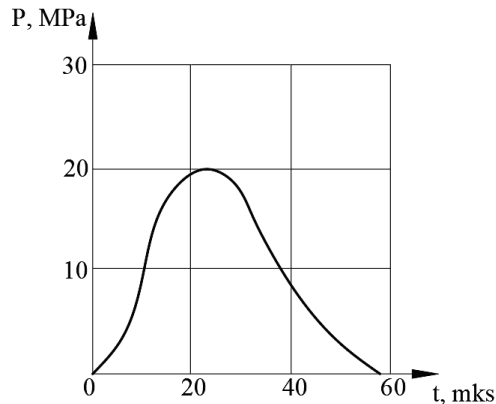

Fig. 1. Dependence of pressure on time at pulse deformation of aluminum pipe: P – pressure; t – time

The method of metal plates cutting by high-head fluid was developed [15]. Solutions of alkali salts or finely dispersed metal powders are added to water to form a jet from current conductive fluid. Then it is influenced by single-polar pulses. When electric current passes through a fluid jet, a water-oxygen mixture in the plasma state is formed due to electrolysis. Dependence of velocity of liquid flowing out of the nozzle and the distance from it to the working table, is of proportional character.

The method of cutting by a high pressure jet with the use of cooled air [16], under the influence of which the jet freezes and a detail is treated in solid state, is promising. Abrasive grains, introduced into the jet structure, perform cutting when in contact with the surface of a part.

There is a known plant [17] for cutting sheet material by the fluid jet of not high pressure, which contains the cutting nozzle fitted with possibility of simultaneous movement due to the device of numerical program control with a jet catcher after cutting. It also contains a support table with a frame that is made in the shape of two identical units, mounted sequentially one after the other, each of which is designed as a set of elements. The specified elements are mounted with possibility to rotate around their axis due to supporting shafts, fixed sequentially with possibility of reciprocating movement in the longitudinal direction and kinematically linked together.

In a number of studies on hydro-cutting with the use of nozzles [18], devices for cutting with the usual water jet [19] and a high pressure jet [20], technological parameters of the process were established. The authors explored specific features of material cutting by a non-high pressure jet [21], both with the use of specialized mouthpieces for nozzles [22], and with the use of high-velocity fluid jet [23]. Particular papers describe the low pressure system of the hydro-cutting plant [24], as well as simulation of the process of destruction of non-metal materials [25]. In this case, due to the selection of rational cutting parameters [26], cutting of some polymeric materials is also provided [27]. There is an article that describes calculation of the profile of jet-forming nozzle channel [28] of hydro cutting plant.

In the above papers, optimal values of technological parameters for cutting textile materials and leather, micropore rubber, leather vinyl and PVC film were established:

- working fluid pressure is 300–400 MPa;
- outlet diameter of the jet-forming mouthpiece (nozzle) is 0.1–0.15 mm;

- distance between the cut of the jet-forming nozzle and the surface of material that is treated is 5–30 mm;
- angle between the axis of the nozzle and the surface of material (attack angle) is 70–110°;
- length of the jet-forming mouthpiece is 5–85 mm.

It was also determined that productivity of hydro-cutting largely depends on the shape of the jet-forming channel of the nozzle [29]. Thus, at the same values of pressure and the outlet diameter, a change in its shape allowed an increase in process productivity by 1.5 times. The best jet formation is provided by nozzles with the conoidal shape of the channel, but high microhardness of material complicates treatment of channels of complex shapes, and therefore, nozzles with a conical-cylindrical channel are more often produced in practice.

To intensify the cutting process due to using a special device [30], it was proposed to add fine abrasive particles to working fluid [31], which made it possible to an increase in the intensity of hydro-abrasive cutting of sheet materials [32, 33] and destructive properties by 10–12 times, as well as to improve performance of the equipment [34]. The optimal parameters for hydro-abrasive cutting of roll and sheet materials for light industry were found [35]:

- pressure of working fluid is 50–200 MPa;
- the outlet diameter of the jet-forming mouthpiece (nozzle) is 1.5 mm;
- the distance between the cut of the jet-forming mouthpiece and the surface of treated material is 1–3 mm;
- the angle between the nozzle axis and the surface of material (attack angle) is 90°;
- the length of the jet-forming mouthpiece is 45–60 mm;
- mass consumption of abrasive material is 2.5–3 g/s.

Quartz sand was used as abrasive material.

The explored technologies make it possible to deform a variety of materials, applying significant loads. The mentioned features can be used when developing a new way of shaping headgear details from fabric, because in this case, FAWM for fabric plasticization. In addition, local pressure is created on the necessary shaping sections when solving the jet motion control problem. Analysis of existing hydro-jet technologies leads to research with the purpose of developing of the shaping method with re-varying load of textile material.

As a result of theoretical analysis, the conclusion about effectiveness of shaping headgear details by the hydro-jet was made. It was established that it is appropriate to place the nozzle so that the semi-axis of elliptic outlet opening δ_{emas} should be in the frontal cross-section of a detail (Fig. 2).

The plant for cutting sheet material by ultrahigh pressure jet is close in essence [17]. The specified plant contains the cutting nozzle, which simultaneously moves along material, and the cutting table that moves across the latter. Synchronous movement of the cutting nozzle and the cutting table is provided by operation of numerical program control device. The disadvantage of this method of cutting is limitation of motion of the working bodies along one of the coordinate axes.

Thus, important factors that provide high quality indicators of hydro-jet technologies include the distance from the nozzle to treated material, jet pressure, which depends on fluid velocity. The angle between the jet's axis and the surface of material, the shape of the jet-forming nozzle, material supply rate relative to the hydro-jet and possibility of the process automation through development of the algorithm of the nozzle's motion relative to the treated detail are also important.

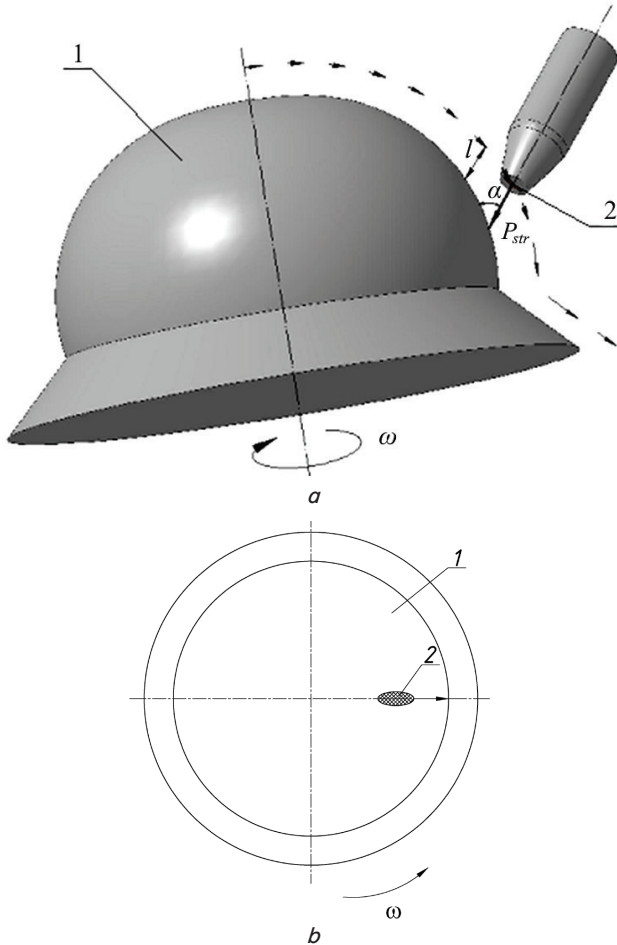

Fig. 2. Schematic of effective location of the conoidal mouthpiece with elliptical outlet opening relative to the surface of the shaped headgear detail: *a* – general view; *b* – view from above; 1 – detail; 2 – outlet opening of mouthpiece

3. The aim and objectives of the study

The aim of present research is the preliminary study of pressure of submerged hydro-jet as a means of expanding women's headgear design opportunities at hospitality establishments.

To accomplish the aim, the following tasks were set:

- to develop an experimental device for determining dynamic pressures of the submerged hydro-jet;
- to develop the method for determining dynamic pressures of the submerged hydro-jet;
- to conduct a pilot study for determining dynamic pressures of the submerged hydro-jet.

4. Analytical and methodological aspects of research into process of hydro-jet formation

4. 1. Development of the device and method for determining dynamic pressure of the submerged hydro-jet

One of the disadvantages of using the hydro-jet in the air space is insufficient fabric plasticization, compared to the use of the submerged stream. In the latter, the fluid of the water layer of working media penetrates threads and fibers and plasticizes fabric, preparing it for the shaping process. Therefore,

the use of the non-submerged hydro-jet is undesirable, as it sometimes leads to destruction of fabric rather than shaping.

In order to conduct research, measuring equipment, which contains sensors and pressure indicators [36, 37], and manometers [38] that are used for determining of fluid pressure in the system, are applied in practice. However, the mentioned devices exclude possibility of measuring dynamic pressure of the submerged hydro-jet.

In order to expand functionality of measuring dynamic pressure of the submerged hydro-jet, we designed a device. The specified pressure is measured at an assigned distance from the end of the jet-forming nozzle to a headgear detail, which is formed by the hydro-jet method (Fig. 3, 4). The developed device contains a two-arm lever, both arms 1 and 2 of which are tightly linked with axis 3 that is fixed in two ball bearings 4, located in handle 5. Arms 1 and 2 are structurally equal, located in one plane, perpendicular to the axis and parallel to each other. At the end of lower arm 2, a platform for the hydro-jet in the shape of disc *S* was mounted. Tie 6, connected with dynamometer *f* was fixed at the end of the upper arm. Platform 7 with the angle measuring devices is placed on handle 5. Here is also the indicator *HL* with power source *G* and adjustable stop 8, which is one of the contacts of group *Q*.

The method for determining dynamic pressure of the submerged hydro-jet is as follows. Handle 5 (Fig. 3) is mounted vertically using supports. Lower arm 2 of the lever is immersed in the fluid so that the axis of the jet-forming nozzle should pass through the center of target *S* and should be perpendicular to the plane of target *S*. In this case, the end of the nozzle is placed at distance *l* from target *S*. The location, necessary for accurate measurement, is controlled in the horizontal plane of water level 9, which provides for accuracy of 15' of the arc, and in the vertical plane, by the angle measuring indicator 10 with accuracy of 1° of arc.

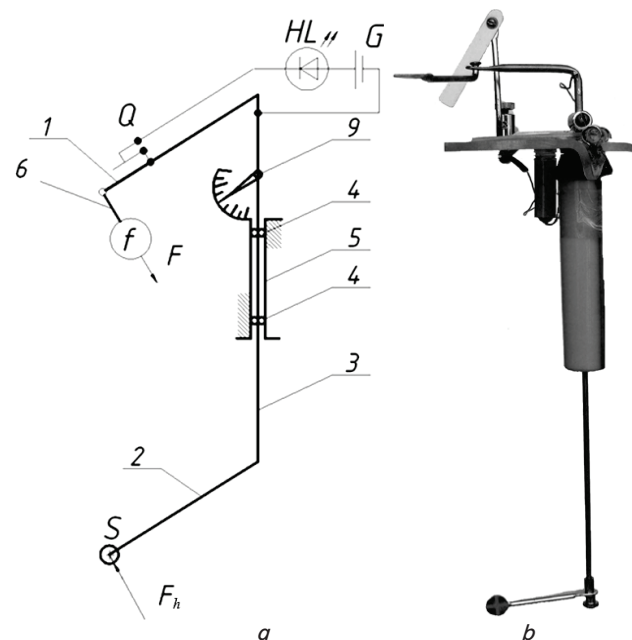

Fig. 3. Image of the developed device for measuring dynamic pressure of the submerged hydro-jet: *a* – kinematic scheme; *b* – overall view: *S* – platform for action of the submerged hydro-jet; *f* – dynamometer; *G* – power source; *Q* – group of contacts; *F* – efforts, applied in reverse direction of hydro-jet operation; *F_h* – force of hydro impact of submerged hydro-jet

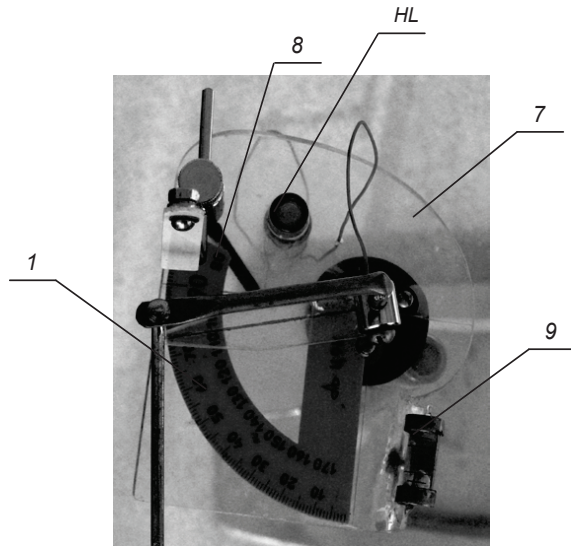

Fig. 4. Image of the upper platform of the developed device for measuring of dynamic pressure of the submerged hydro-jet: HL – indicator; 1, 2 – lever arm; 3 – axis; 4 – ball bearings; 5 – grip; 6 – tie; 7 – platform with angle measuring devices; 8 – adjustable stop; 9 – level; 10 – angle measuring indicator

Next, the pump, which feeds FAWM to the jet-forming mouthpiece, is turned on. As a result of the action of the hydro-jet, the two-arm lever turns around axis 3 in bearings 4 to stop 8, which causes contact closure Q and turning on of the led indicator HL.

Next, through hinge tie 6, mechanical effort F is applied, which is controlled by dynamometer f , reverse to the vector of hydro-jet action, which is achieved by location of hinge tie 6 according to the indicated line on platform 7. Thus, the lever starts to rotate in reverse direction, which causes contacts closure Q and turns off the led indicator HL. Stop 8 is regulated so that the moment of disconnection of contacts Q corresponds to the angle of the hydro-jet fall on target S , equal to 90° . At this point, the value, which corresponds to magnitude of the hydro impact force of the submerged hydro-jet, is recorded on the digital scoreboard of the dynamometer. In this case, module F equals to module F_h .

Next, dynamic pressure of the submerged hydro-jet is derived from the following formula:

$$P_{d\ str} = \frac{F_h}{S_{str}}, \tag{1}$$

where F_h is the force of the jet's hydro impact; S_{str} is the cross-section area of the submerged hydro-jet at distance l from the end of the mouthpiece.

The developed device is capable to receive dynamic loads at the distance of 1–30 mm between the cut of the jet-forming nozzle and the surface of treated material. Maximal pressure of working medium is 150 MPa.

Therefore, the set problem is solved so that measurement of pressure of the submerged hydro-jet should be performed by measuring forces of reaction, the module of which is equal to pressure module, as the vector is reverse. This is due to the transfer of action of forces from the fluid to the air medium with the help of the two-arm lever [39].

The use of the developed device and the method will make it possible to explore a change in magnitude of dynamic pressure of the submerged hydro-jet depending on the geometrical parameters of mouthpieces.

4. 2. Research methods

Specific value of the forming effort for a certain unit of the contact area of a detail is equal to magnitude of dynamic pressure of the submerged hydro-jet.

Using the method for calculation of geometrical parameters of jet-forming mouthpieces and the submerged hydro-jets, formed by them [40], corresponding dimensions of the inlet, outlet diameters, reduced length of mouthpieces and contact areas of the formed hydro-jets, were determined. Calculations were carried out at the distance of 5, 10, 15, 20 and 25 mm from the end to the surface of the shaped detail for ten conoidal mouthpieces with round or elliptical outlet openings.

For conducting experimental research, a series of mouthpieces (Table 1, 2) with geometric parameters, shown in Fig. 5, was fabricated.

Table 1

Values of geometric parameters of conoidal mouthpieces with round outlet openings and jets, formed by them

No. of entry	L_1 , mm	L_2 , mm	D_{nas} , mm	d_{nas} , mm	r_{nas} , mm	X_p , mm	r_p , mm
1	1	10	10	1	0.5	4.2	0.9
2	1.5	15	10	1.5	0.75	6.3	1.3
3	2	20	10	2	1	8.4	1.8
4	2.5	25	10	2.5	1.25	10.5	2.2
5	3	30	10	3	1.5	12.6	2.6

Note: L_1, L_2 are the lengths of the cylindrical and conoidal parts of the mouthpiece, respectively, D_{nas}, d_{nas} are the inlet and outlet diameters of the mouthpiece, respectively, r_{nas} is the radius of the mouthpiece, X_p is the initial section of the submerged hydro-jet with round inlet openings, r_p is the radius of the jet in the transition cross-section

Table 2

Values of geometrical parameters of conoidal mouthpieces with elliptical outlet openings and jets, formed by them

No. of entry	L_1 , mm	L_2 , mm	D_{nas} , mm	$\delta_{a\ nas}$, mm	$\delta_{b\ nas}$, mm	X'_n , mm	δ_{ap} , mm	δ_{vp} , mm
1	1	10	10	0.2	1.3	2.1	0.7	1.7
2	1.5	15	10	0.3	1.9	3.1	1	2.6
3	2	20	10	0.4	2.5	4.1	1.4	3.5
4	2.5	25	10	0.5	3.1	5.2	1.7	4.4
5	3	30	10	0.6	3.8	6.2	2.1	5.2

Note: $\delta_{a\ nas}, \delta_{b\ nas}$ are the semi-axes of the elliptical outlet opening of the mouthpiece, X'_n is the initial section of the submerged hydro-jet with elliptic outlet openings, δ_{ap}, δ_{vp} are the semi-axes of the jet in transition cross-section



Fig. 5. Physical appearance of conoidal jet-forming mouthpieces with round (bottom row) and elliptical (top row) outlet openings

Values of dynamic pressures of submerged hydro-jets $P_{d\,str}$, created by the given conoidal nozzles, were calculated.

5. Results of the study into determining dynamic pressures of the submerged hydro-jet

As a result of the experimental studies, dynamic pressures of submerged hydro-jets, formed by five conoidal mouthpieces [with round outlet openings (Fig. 6) and five mouthpieces with elliptical outlet openings were determined (Fig. 7).

Dependences of changes in dynamic pressure of the submerged hydro-jet on the distance between the mouthpiece and the detail are shown in Table 3.

Degree of approximation reliability R^2 was established, and it was determined that the obtained equations with sufficient accuracy (5 %) reproduce actual dependence, because R^2 in all cases tends to unity and is located within 0.96–0.99.

Graphic dependences of a change in dynamic pressure of the submerged hydro-jet on the distance between the end of the conoidal mouthpiece and the surface of a detail are shown in Fig. 8.

As charts (Fig. 8) show, dynamic pressure of the submerged hydro-jet tends to increase with decreasing of a distance between the end of a nozzle and the surface of a detail. This can be explained as follows: as the distance from the outlet opening increases, the hydro-jet is diffused by the near-boundary layer of FAWM, which surrounds it, resulting in a decrease in intensity of hydro-jet influence.

Comparative analysis of theoretical and experimental data (Table 4, 5) showed that calculation values exceed the experimental ones due to FAWM pressure losses, which occur as a result of friction on the wall of a nozzle and operation of research equipment.

Thus, the use of the designed device and method allowed studying a change in magnitude of dynamic pressure of the submerged hydro-jet depending on geometrical parameters of mouthpieces, in particular conoidal mouthpieces with round and elliptical outlet openings.

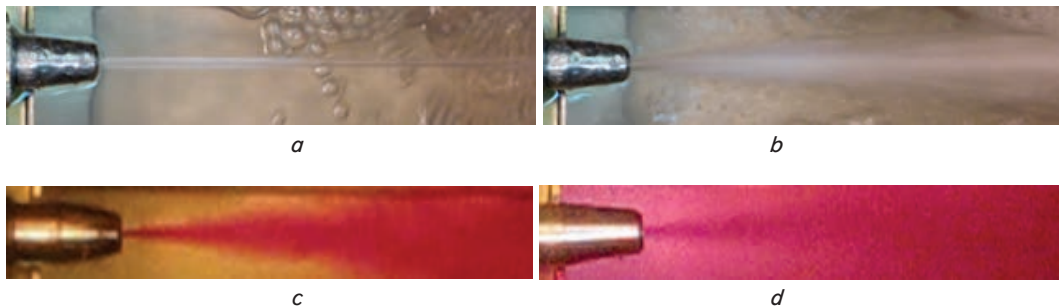

Fig. 6. Structure of hydro-jets, formed by conoidal mouthpieces with elliptical outlet opening: *a* – in air space; *b* – at immersion in water; *c* – of submerged hydro-jet (nozzle No. 1); *d* – of submerged hydro-jet (nozzle No. 5)

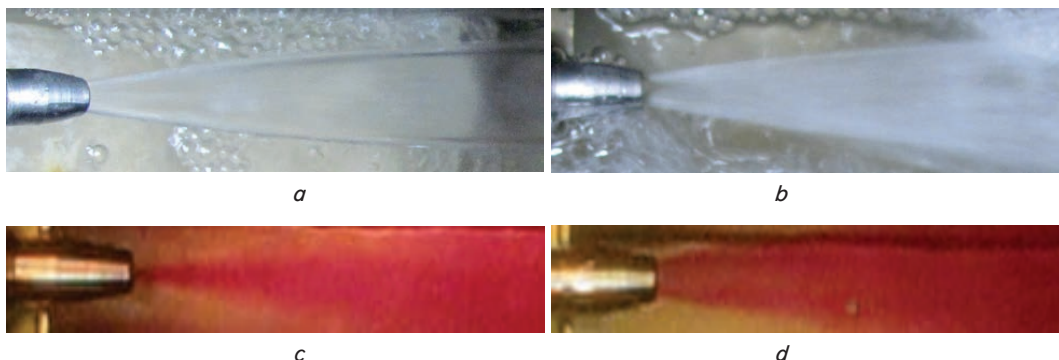

Fig. 7. Structure of hydro-jets, formed by conoidal mouthpieces with round outlet opening: *a* – in air space; *b* – at immersion in water; *c* – of submerged hydro-jet (nozzle No. 1); *d* – of submerged hydro-jet (nozzle No. 5)

Table 3

Dependences $P_{d\ str} = f(l)$

Shape of the outlet opening (R – round; E – elliptical) and mouthpiece number	Dependences of changes in dynamic pressure of the submerged hydro-jet on the distance between the mouthpiece and the detail	Reliability of approximation R^2
R1	$P_{d\ str} = 0.000104l^2 - 0.0017l + 0.0163$	0.97
R2	$P_{d\ str} = 0.000106l^2 - 0.0024l + 0.0265$	0.98
R3	$P_{d\ str} = 0.0001l^2 - 0.003l + 0.0336$	0.98
R4	$P_{d\ str} = 0.0001l^2 - 0.0041l + 0.0474$	0.99
R5	$P_{d\ str} = 0.0001l^2 - 0.0046l + 0.0551$	0.99
E1	$P_{d\ str} = 0.00001l^2 - 0.0006l + 0.0072$	0.97
E2	$P_{d\ str} = 0.0001l^2 - 0.0027l + 0.0278$	0.96
E3	$P_{d\ str} = 0.00011l^2 - 0.0029l + 0.0334$	0.98
E4	$P_{d\ str} = 0.0001l^2 - 0.0034l + 0.0407$	0.97
E5	$P_{d\ str} = 0.0001l^2 - 0.0048l + 0.056$	0.96

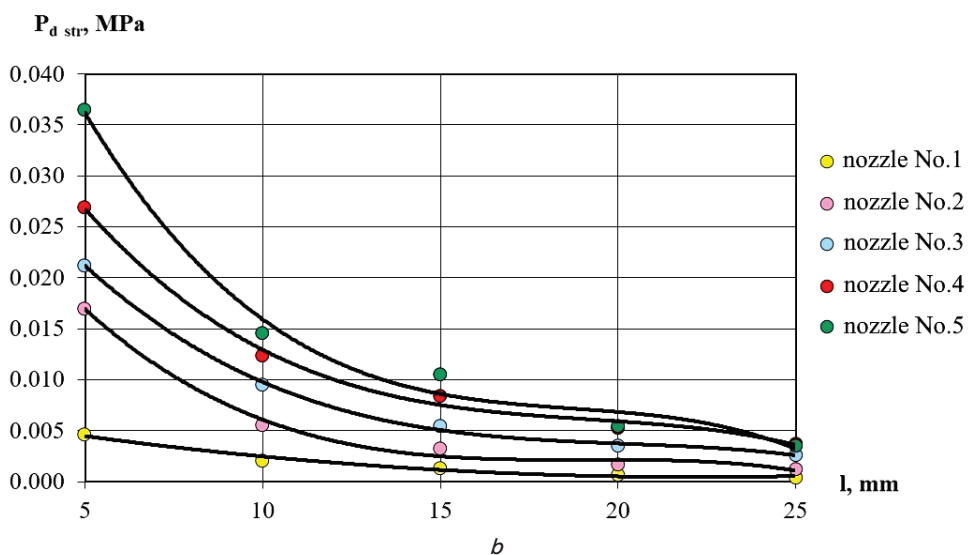
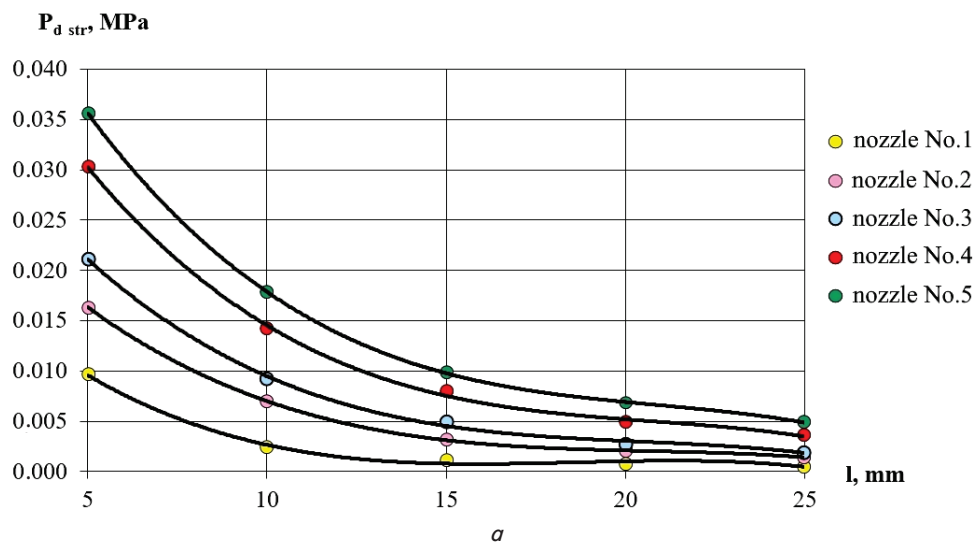

Fig. 8. Dependence of change in dynamic pressure of the submerged hydro-jet on the distance between the face of a conoidal mouthpiece and the surface of a headgear detail: 1–5 are nozzle number; a – for nozzles with round outlet openings; b – for nozzles with elliptical outlet openings; $P_{d\ str}$ is the dynamic pressure of the jet; l is the distance from the end of the nozzle to the surface of a detail

Table 4

Experimental and calculation values of dynamic pressures of submerged hydro-jets, formed by conoidal nozzles with round outlet opening

No. of nozzle	l , mm	d_{nas} , mm	S_{nas} , mm ²	S_{str} , mm ²	$P_{d\ str\ exper}$, MPa	$P_{d\ str\ rozt}$, MPa	ΔP , MPa
1	5	1	0.8	10.9	0.0096	0.0108	0.0012
	10			32.6	0.0024	0.0036	0.0012
	15			65.9	0.0012	0.0018	0.0006
	20			110.8	0.0008	0.0011	0.0003
	25			167.3	0.0005	0.0007	0.0002
2	5	1.5	1.8	14.0	0.0163	0.0189	0.0026
	10			37.8	0.0070	0.0070	0.00003
	15			73.3	0.0032	0.0036	0.0004
	20			120.3	0.0021	0.0022	0.0001
	25			179.0	0.0014	0.0015	0.00006
3	5	2	3.1	17.5	0.0217	0.0269	0.0052
	10			43.5	0.0092	0.0108	0.0016
	15			81.0	0.0050	0.0058	0.0008
	20			130.2	0.0028	0.0036	0.0009
	25			191.0	0.0019	0.0025	0.0005
4	5	2.5	4.9	21.4	0.0303	0.0344	0.0041
	10			49.5	0.0142	0.0149	0.0006
	15			89.2	0.0080	0.0082	0.0003
	20			140.5	0.0049	0.0052	0.0003
	25			203.5	0.0036	0.0036	0.00006
5	5	3	7.1	25.7	0.0356	0.0412	0.0056
	10			55.9	0.0178	0.0190	0.0011
	15			97.8	0.0098	0.0108	0.0010
	20			151.2	0.0069	0.0070	0.0001
	25			216.3	0.0049	0.0049	0.00003

Note: l is the distance from the end of the nozzle to the contact platform, S_{nas} is the area of outlet opening of the mouthpiece, S_{str} is the area of transition cross-section of submerged hydro-jet, $P_{d\ str\ exper}$ is the experimental dynamic pressure of the submerged hydro-jet, $P_{d\ str\ rozt}$ is the calculated dynamic pressure of the submerged hydro-jet, ΔP is the deviation between the calculated and experimental values of the dynamic pressure of the submerged hydro-jet

Table 5

Experimental and calculation values of dynamic pressures of submerged hydro-jets, formed by conoidal mouthpieces with elliptical outlet opening

No. of nozzle	l , mm	$\delta_{a\ nas}$, mm	$\delta_{b\ nas}$, mm	S_{nas} , mm ²	S_{str} , mm ²	$P_{d\ str\ exper}$, MPa	$P_{d\ str\ rozt}$, MPa	ΔP , MPa
1	5	0.2	1.3	0.8	11.0	0.0047	0.0111	0.0065
	10				30.2	0.0020	0.0041	0.0020
	15				58.5	0.0014	0.0021	0.0007
	20				95.8	0.0007	0.0013	0.0006
	25				142.1	0.0004	0.0009	0.0004
2	5	0.3	1.9	1.8	14.6	0.0170	0.0184	0.0014
	10				36.5	0.0056	0.0074	0.0017
	15				67.4	0.0032	0.0040	0.0008
	20				107.3	0.0017	0.0025	0.0008
	25				156.3	0.0012	0.0017	0.0005
3	5	0.4	2.5	3.1	18.6	0.0212	0.0253	0.0041
	10				43.1	0.0095	0.109	0.0014
	15				76.6	0.0054	0.0061	0.0007
	20				119.2	0.0035	0.0039	0.0004
	25				170.8	0.0027	0.0028	0.0001
4	5	0.5	3.1	4.9	23.0	0.0269	0.0317	0.0048
	10				50.1	0.0124	0.0146	0.0022
	15				86.3	0.0084	0.0085	0.0001
	20				131.5	0.0054	0.0055	0.0002
	25				185.7	0.0037	0.0039	0.0002
5	5	0.6	3.8	7.1	28.3	0.0365	0.0374	0.0009
	10				58.4	0.0146	0.0181	0.0036
	15				97.6	0.0106	0.0109	0.0002
	20				145.8	0.0055	0.0073	0.0018
	25				293.1	0.0035	0.0036	0.0001

6. Discussion of results regarding the use of submerged hydro-jet for headgear shaping

To determine dynamic pressures of submerged hydro-jets, losses coefficient, which is calculated from the following formula, was introduced:

$$K_b = \frac{P_{d\ str\ exper}}{P_{d\ str\ rozr}}, \quad (2)$$

where $P_{d\ str\ exper}$ is the experimental value of dynamic pressure of the submerged hydro-jet, MPa; $P_{d\ str\ rozr}$ is the calculation value of dynamic pressure of the submerged hydro-jet, MPa.

For rational operation of the studied equipment, the following condition must be satisfied: $0 < K_b < 1$.

The average value of losses coefficient for this type of equipment K_b is from 0.66 to 0.99 when using conoidal mouthpieces with circular outlet openings and $K_b=0.42-0.99$ when using conoidal mouthpieces with an elliptical outlet opening.

By analyzing the obtained results, it is possible to conclude that the experimental values of dynamic pressures of the hydro-jets, formed by nozzles No. 3–5, are within the specific formation effort, (0.02–0.12 MPa), and losses do not exceed the permissible value.

The developed device provides measurement of magnitude of dynamic pressure of the submerged hydro-jet, which is used for headgear shaping. However, for higher quality shape stability of products, it is necessary to improve accuracy of measurement of hydro-jet pressure. To do this, it is required to conduct a series of additional studies and improvements of the existing device that will provide improvement of measurement.

The developed method makes it possible to determine a change in magnitude of dynamic pressure of the submerged hydro-jet depending on the geometrical parameters of the mouthpieces, used for women's headgear shaping at hospitality establishments. However, efficient use of the latter requires special equipment.

Modern technologies and equipment for headgear shaping do not provide reliable fixation of workpieces and their sufficient shape stability. As a rule, usual stitching of workpieces or adding glue solutions are used for better shaping.

In this case, there are no specialized shaping plants or automated equipment. That is why development of a research plant for high quality shaping of women's headgear at hospitality establishments with the use of the developed device and method is a promising task.

7. Conclusions

1. An analysis of the application of hydro-jet technologies in various industries was performed, and factors that provide high quality indicators were established, in particular: pressure of working fluid, the outlet diameter of the jet-forming mouthpiece (nozzle), the distance between the cut of the jet-forming nozzle and the surface of the treated material, the angle between the axis of the nozzle and the surface of material (attack angle), the length of the jet-forming nozzle.

2. The experimental device for determining dynamic pressures of the submerged hydro-jet was developed. The application of the device made it possible to explore the influence of geometric parameters of conoidal jet-forming mouthpieces with round and elliptical outlet openings on magnitude of dynamic pressures of the submerged hydro-jets, formed by them. The device operates at the distance of 1–30 mm between the cut of the jet-forming mouthpiece and the surface of treated material at maximum pressure of working medium of 150 MPa.

3. The method was developed for determining dynamic pressures of the submerged hydro-jet depending on geometrical parameters of the mouthpiece used for women's headgear shaping at hospitality establishments. The method makes it possible to obtain the power of the jet hydro impact depending on the area of the cross-section of the submerged hydro-jet at a fixed distance from the end of the mouthpiece, which allows the calculation of necessary parameters of pressure in the range from 0.01 to 10 MPa.

4. As a result of conducted research it was found that the experimental values of dynamic pressures of the hydro-jet are in the range of specific forming effort from 0.02 to 0.12 MPa. The mean value of coefficient of losses is $K_b=0.66-0.99$ when using conoidal mouthpieces with a round outlet opening, and $K_b=0.42-0.99$ when using conoidal mouthpieces with an elliptical outlet opening.

References

1. Study of cutting presses in designing a women's costume for hospitality industry / Yakymchuk D., Yakymchuk O., Chepeliuk O., Myrhorodska N., Koshevko J., Orlenko O., Nosova I. // Eastern-European Journal of Enterprise Technologies. 2017. Vol. 5, Issue 1 (89). P. 26–36. doi: 10.15587/1729-4061.2017.110962
2. Yakymchuk O. V., Yakymchuk D. M., Myrhorodska N. V. Innovative feminine Indian suit as an inspiration of clothes design of hospitality establishments // Science and Education a New Dimension. Humanities and Social Sciences. 2017. Vol. 23, Issue 139. P. 7–9.
3. Simulation of a high-pressure water jet structure as an innovative tool for pulverizing copper ore in KGHM Polska Miedz S. A. / Borkovski J., Shimizu S., Peng G., Oguma Y. // Mining Science. 2015. Vol. 22. P. 147–159. doi: 10.5277/msc152212
4. Zakharkevich O. V., Kuleshova S. G. Development of the method of scaling patterns and virtual garments forms // Vlakna a Textil. 2017. Vol. 4. P. 34–40.
5. Cui L., An L., Gong W. Optimizing process parameters of high pressure water jet mill. The 8th Pacific Rim International Conference on Water Jet Technology. 2006. P. 138–145.
6. Peng G., Shimizu S., Fujikawa S. Numerical simulation of Turbulent Cavitating Water Jets Issued from a Submerged Orifice Nozzle // 9th Pacific Rim International Conference on Water Jetting Technology. 2009. P. 139–144.
7. Shimizu S., Shinoda Y., Peng G. Flow characteristics of water jet issuing from a fan jet nozzle // 19th International Conference on Water Jetting. BHR Group Ltd., UK, 2008. P. 55–65.

8. Shimizu S. Structure and erosive characteristics of water jet issuing from fan jet nozzle // 18th International Conference on Water Jetting. 2006. P. 337–345.
9. Observations of cavitating jets issuing from a sheathed nozzle / Ito H., Aoyama T., Peng G., Shimizu S. // 9th Pacific Rim International Conference on Water Jetting Technology. 2009. P. 97–100.
10. Seminska N. Hidrostrumynni metody ruinuвання materialiv // Mashynoznavstvo. 2007. Issue 5. P. 22–25.
11. Atanov G. A. Gidroimpul'snye ustanovki dlya razrusheniya gornyh porod. Kyiv: Vyscha shkola, 1987. 155 p.
12. Stepanov V. G., Shavrov I. A. Vysokoenergeticheskie impul'snye metody obrabotki materialov. Leningrad: Mashinostroenie, 1975. 280 p.
13. Lamekin N. S. Kavitatsiya: teoriya i primenenie. Moscow: RUSAKI, 2000. 248 p.
14. Fedotkin I. M., Guliy I. S. Kavitatsiya. Kavitatsionnye energeticheskie apparaty i ustanovki. Kyiv: Arktur-A, 1998. 131 p.
15. Sposob rezki vysokonapornoy struey zhidkosti i ustroystvo dlya ego osushchestvleniya: A. s. No. 1377172a SSSR. MKI4 B 23 D 31/00 / Plyuta V. E., Sivakov A. L., Gorchakov G. M., Kordochkin B. A. No. 4079367/25-27; declared: 20.06.1986; published: 29.02.1988, Bul. No. 8.
16. Sposob gidrostruynoy rezki listovykh materialov: A. s. No. 159162a SSSR. MKI5 B 23 D 31/00 / Burlyka A. F., Shul'man G. M., Fridman R. A., Guenko V. S., Zenkin A. S., Larionov M. T. No. 3607698/25-27; declared: 13.06.1983; published: 30.06.1985, Bul. No. 24.
17. Sokolov N. Yu., Zadonin A. S. Ustanovka dlya rezki listovogo materiala struy zhidkosti sverhvyssokogo davleniya: A. s. No. 1734964 SSSR. MKI5 V23 D 31/00. No. 4800884/27; declared: 30.01.1990; declared: 23.05.1992, Bul. No. 19.
18. Soplo k ustroystvu dlya rezki zhidkost'yu vysokogo davleniya: A. s. No. 1466875a SSSR. MKI4 B 23 D 31/00 / Tihomirov R. A., Kovalev Yu. V., Petuhov E. N., Starikov I. D. No. 4259091/31-27; declared: 17.04.1987; published: 23.03.1989, Bul. No. 11.
19. Ustroystvo dlya rezki struey vody: A. s. No. 1549679a SSSR. MKI5 B 23 D 31/00 / Novikov V. A., Arhipov A. N., Shoshin V. G., Savateev A. N. No. 4310033/20-27; declared: 28.09.1987; published: 15.03.1990, Bul. No. 10.
20. Kisilev O. P., Kukishev V. M. Ustroystvo dlya rezki struey zhidkosti vysokogo davleniya: A. s. No. 1311871a SSSR. MKI4 B 23 D 31/00. No. 3817738/25-27; declared: 29.11.1984; published: 23.05.1987, Bul. No. 19.
21. Tsabinski Z., Kyupper G., Birvert K. Raskroynny portal ustanovki dlya raskroya materiala struey zhidkosti sverhvyssokogo davleniya: Pat. No. 1639423a SSSR. MKI5 B 23 D 31/00, B 26 F 3/00. No. 4203511/27; declared: 21.10.1987; published: 30.03.1991, Bul. No. 11.
22. Nasadka sopla: A. s. No. 1409420a SSSR. MKI4 B 23 D 31/00 / Belyaev S. V., Kedrovskiy B. G., Klaptsov Yu. V., Petko I. V., Yankin L. N., Kudryavtsev K. K. No. 4128679/31-27; declared: 15.08.1986; declared: 15.07.1988, Bul. No. 26.
23. Sposob rezaniya vysokoskorostnoy struey zhidkosti: A. s. No. 1433660a SSSR. MKI4 B 23 D 31/00 / Belyaev S. V., Kedrovskiy B. G., Klaptsov Yu. V., Petko I. V., Slobodyanyuk V. A. No. 4206762/28-27; declared: 09.03.1987; declared: 30.10.1988, Bul. No. 40.
24. Petko I. V., Slobodyanyuk V. A. Analiticheskoe issledovanie sostoyaniya sistemy nizkogo davleniya gidroreznoy ustanovki vo vremya pereklyucheniya gidroraspredelatelya // Izvestiya vysshih uchebnykh zavedeniy. Tekhnologiya legkoy promyshlennosti. 1989. Issue 5. P. 125–127.
25. Petko I. V., Kedrovskiy B. G. Modelirovanie protsessa razrusheniya nemetallicheskih materialov gidrostruey vysokogo davleniya // Izvestiya vysshih uchebnykh zavedeniy. Tekhnologiya legkoy promyshlennosti. 1987. Issue 4. P. 127–131.
26. Petko I. V., Slobodyanyuk V. A. Obespechenie stabil'nosti istecheniya strui zhidkosti za schet vybora ratsional'nykh parametrov gidroreznoy ustanovki // Izvestiya vysshih uchebnykh zavedeniy. Tekhnologiya legkoy promyshlennosti. 1992. Issue 5-6. P. 93–95.
27. Kedrovskiy B. G., Petko I. V. Eksperimental'noe issledovanie proizvoditel'nosti protsessa raskroya nekotorykh polimernykh materialov struey zhidkosti vysokogo davleniya // Izvestiya vysshih uchebnykh zavedeniy. Tekhnologiya legkoy promyshlennosti. 1987. Issue 6. P. 124–126.
28. Belyaev S. V., Petko I. V. K raschetu profilya kanala strueformiruyushchego sopla gidroreznoy ustanovki vysokogo davleniya // Izvestiya vysshih uchebnykh zavedeniy. Tekhnologiya legkoy promyshlennosti. 1988. Issue 3. P. 103–106.
29. Kedrovskiy B. G., Klaptsov Yu. V. Perspektivy ispol'zovaniya protsessa gidrorezaniya // Legka promislolist'. 1988. Issue 3. P. 20–21.
30. Mutin F. I., Habibullin M. N. Ustroystvo dlya rezki materialov: A. s. No. 1671420 a SSSR. MKI5 B 23 D 31/00. No. 4605253/27; declared: 15.11.1988; published: 23.08.1991, Bul. No. 31.
31. Petko I. V., Klaptsov Yu. V., Slobodyanyuk V. A. Opredelenie energeticheskikh harakteristik abrazivno-zhidkostnoy strui // Izvestiya vysshih uchebnykh zavedeniy. Tekhnologiya legkoy promyshlennosti. 1988. Issue 4. P. 130–134.
32. Petko I. V., Klaptsov Yu. V., Slobodyanyuk V. A. Eksperimental'noe issledovanie intensivnosti gidroabrazivnogo rezaniya listovykh materialov. Soobshchenie 1 // Izvestiya vysshih uchebnykh zavedeniy. Tekhnologiya legkoy promyshlennosti. 1988. Issue 5. P. 114–117.
33. Petko I. V., Klaptsov Yu. V., Slobodyanyuk V. A. Eksperimental'noe issledovanie intensivnosti gidroabrazivnogo rezaniya listovykh materialov. Soobshchenie 2 // Izvestiya vysshih uchebnykh zavedeniy. Tekhnologiya legkoy promyshlennosti. 1988. Issue 6. P. 102–104.
34. Klaptsov Yu. V., Petko I. V., Panasiuk I. V. Doslidzhennia vplyvu konstruktyvnykh parametriv ustatkuvannia na produktyvnist hidroabrazivnogo rizannia // Visnyk Khmelnytskoho natsionalnoho universytetu. 2007. Issue 1. P. 25–28.
35. Klaptsov Yu. V., Panasiuk I. V., Petko I. V. Vyznachennia konstruktyvnykh parametriv strumeneformuiuchoho prystroiu // Visnyk Khmelnytskoho natsionalnoho universytetu. 2013. Issue 3. P. 115–118.
36. Boryslavskiy H. M., Sirotkin O. A., Sydiak V. O. Datchyk tysku: Pat. No. 32727 A UA. G 01 L/00. No. 20021210166; declared: 17.12.2002; published: 15.05.2006, Bul. No. 5. 4 p.

37. Indykator tysku dlia vohnehasnyka: Pat. No. 6956 S1 UA. G 01 L 7/00 / Voropaiev V. M., Zhylin O. M., Plaksov S. V., Plotnikov V. V. No. 94061590; declared: 16.06.1993; published: 31.03.1995, Bul. No. 1. 3 p.
38. Preobrazhenskiy V. P. Teplotekhnicheskie izmereniya i pribory. Moscow: Energiya, 1978. 704 p.
39. Zlotnikov V. O., Popovych O. V., Kushchevskiy M. O. Prystriyi dlia vymiriuvannya dynamichnoho tysku zatoplenoho hidro strumennia: Pat. No. 55669 UA. G01L 7/00. No. u201000403; declared: 18.01.2010; published: 10.09.2010, Bul. No. 17. 3 p.
40. Yakymchuk O. V., Sidletskiy I. O., Kushchevskiy M. O. Pro vplyv heometrychnykh parametriv nasadkiv ta zatoplenoho hidrostrumennia na yakist formuvannya ob'iemnykh detalei holovnykh uboriv // Visnyk Zhytomyrskoho derzhavnogo tekhnolohichnoho universytetu. 2010. Issue 2. P. 61–67.

Розглянуто задачу аналітичного визначення навантаженості безвершинних різальних кромок торцевої фрези зі спірально-ступінчастим розташуванням ножів. Розроблено математичну модель визначення елементів зрізу в довільному положенні ножів фрези на дузі контакту, достовірність якої підтверджена імітаційним моделюванням. Виявлено залежності величини елементів зрізу від конструктивних параметрів фрези та подачі

Ключові слова: торцеве фрезерування, елементи зрізу, ступінчасті схеми різання

Рассмотрена задача аналитического определения загрузки безвершинных режущих кромок торцевой фрезы со спирально-ступенчатым расположением ножей. Разработана математическая модель определения элементов среза в произвольном положении ножей фрезы на дуге контакта, достоверность которой подтверждена имитационным моделированием. Выявлены зависимости величины элементов среза от конструктивных параметров фрезы и подачи

Ключевые слова: торцевое фрезерование, элементы среза, ступенчатые схемы резания

UDC 621.914

DOI: 10.15587/1729-4061.2018.121712

MODELLING THE LOADING OF THE NOSE-FREE CUTTING EDGES OF FACE MILL WITH A SPIRAL-STEPPED ARRANGEMENT OF INSERTS

L. Hlembotska

Assistant*

E-mail: gle.tmkts@gmail.com

P. Melnychuk

Doctor of Technical Sciences, Professor**

E-mail: meln_pp@ukr.net

N. Balytska

PhD**

E-mail: balytskanataliia@gmail.com

O. Melnyk

PhD*

E-mail: o.l.melnyk@ukr.net

*Department of branch of Machine Building***

Department of Applied Mechanics and Computer-Integrated Technologies*

***Zhytomyr State Technological University
Chudnivska str., 103, Zhytomyr, Ukraine, 10005

1. Introduction

Face mills are widely used both in roughing, semi-finishing and finishing of flat surfaces of machine parts. Raising the productivity of milling such surfaces is an acute problem of modern machine building and can be achieved by increasing feed and/or cutting rate. In turn, intensification of cutting rate necessitates the use of super-hard tool materials which dramatically increases machining costs, especially for multi-toothed tools. Besides, rise of cutting modes worsens dynamic state of the technological processing system and limits the possibility of improvement of machining produc-

tivity. Therefore, it is necessary to develop advanced designs of face mills characterized by a better dynamic stability of the machining process, calculated for machining conditions with larger feeds and providing required surface quality. These include mills with spiral-stepped cutting schemes having nose-free cutting edges and featuring different cut areas for different inserts.

The decision on appropriateness of using a tool of a particular design cannot be made without analysis of peculiarities of its cutting edge loading. The process of face milling is characterized by impacts occurring at the entrance/exit of the insert to/from the cutting zone, variability of the chip